



*Call today for price and product information.  
Your area representative will assist you promptly.*

## LOUISIANA

8275 Florida Avenue  
Denham Springs, LA 70726  
Ph: 225-665-1666 • Fax: 225-665-4342

3017 21st Street, Suite 209  
Metairie, LA 70002  
Ph: 504-833-7867 • Fax: 504-833-1755

1101 Shady Grove Blvd.  
Bossier City, LA 71112  
Ph: 318-747-5443 • Fax: 318-747-6327

1705 Link Dr.  
Ruston, LA 71270  
Ph: 318-251-9001 • Fax: 318-251-9002

127 Lafferty Drive  
Broussard, LA 70518  
Ph: 337-837-9696 • Fax: 337-837-1717

## MISSISSIPPI

5249 Hwy 80  
Vicksburg, MS 39183  
Ph: 601-638-8900 • Fax: 601-638-8902

## ALABAMA

5454 Able Court  
Mobile, AL 36693  
Ph: 251-666-1414 / 251-602-1688  
Fax: 251-661-0749 / 251-602-1686

## TENNESSEE

6468 Baird Lane  
Bartlett, TN 38135  
Ph: 901-486-4285

## ON THE WEB

[www.deltaprocess.com](http://www.deltaprocess.com)

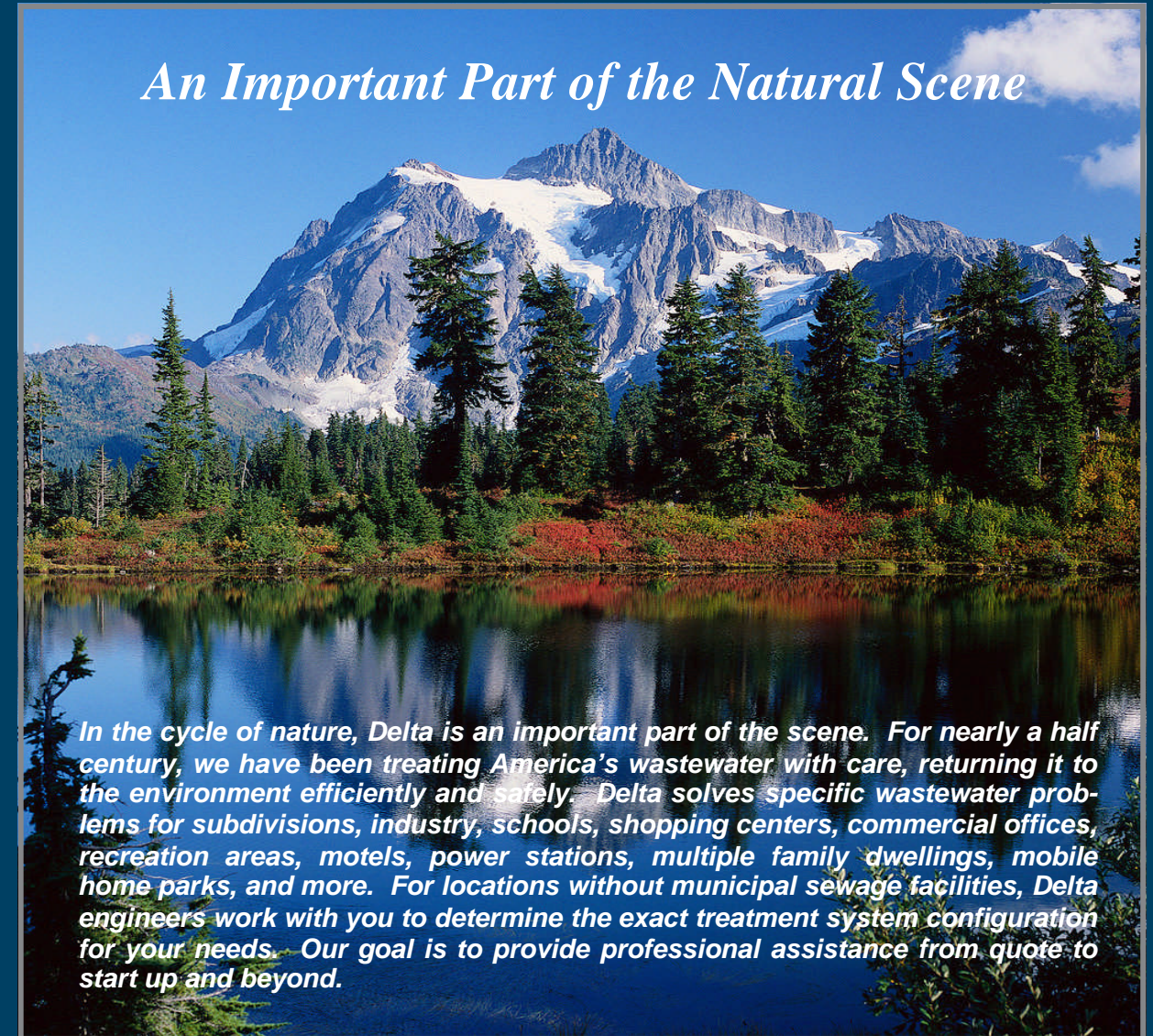

### *An Important Part of the Natural Scene*

*In the cycle of nature, Delta is an important part of the scene. For nearly a half century, we have been treating America's wastewater with care, returning it to the environment efficiently and safely. Delta solves specific wastewater problems for subdivisions, industry, schools, shopping centers, commercial offices, recreation areas, motels, power stations, multiple family dwellings, mobile home parks, and more. For locations without municipal sewage facilities, Delta engineers work with you to determine the exact treatment system configuration for your needs. Our goal is to provide professional assistance from quote to start up and beyond.*

### Our Products

Delta's Extended Aeration Plant is an activated sludge process which allows bacteria to multiply and break down sewage into clear, odorless effluent. The effluent is ready for disinfection with minimal land use, while adhering to state and federal requirements for sewage treatment. Delta Process Sewage Treatment Plants are designed to handle capacities up to 300,000 gallons per day and include aeration tank, clarifier and disinfection tank. Should your facility grow beyond its initial size, Delta Process plants are suitable for easy expansion of capacity.





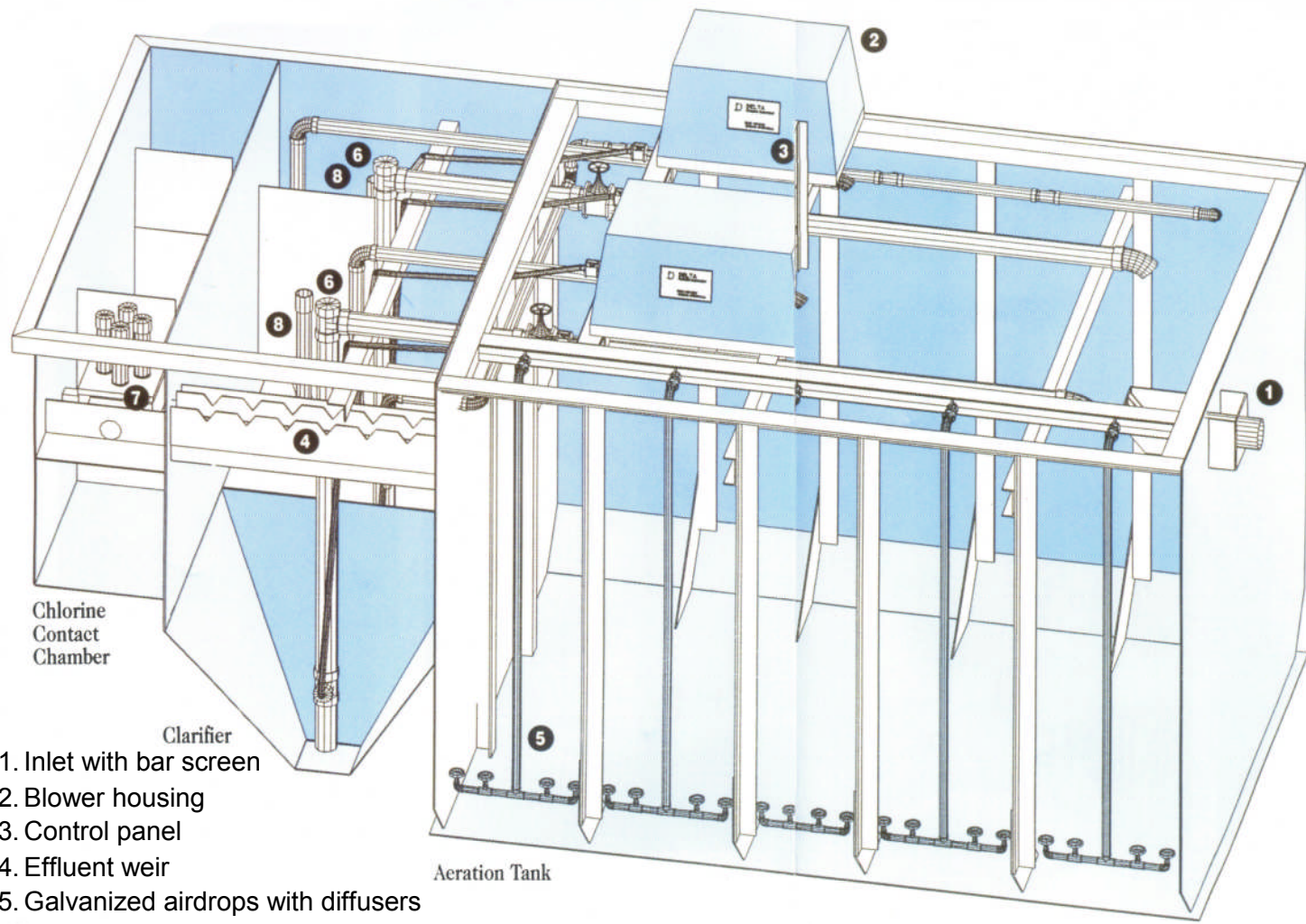

1. Inlet with bar screen
2. Blower housing
3. Control panel
4. Effluent weir
5. Galvanized airdrops with diffusers
6. Sludge return pump
7. Chlorinator
8. Skimmer

### Ancillary Products

For custom applications, Delta maintains a full line of ancillary products including:

- Influent / effluent packaged lift stations
- Tertiary filters
- Sludge holding tanks
- Froth spray systems
- Flowmeters
- Electrical control panels
- Pumps:
  - Self-priming
  - Submersible
  - Solids handling
  - Grinder
- UV Disinfection
- Variable frequency drives
- Instrumentation
- Metering
  - Sludge
- Aerators

### Our Services

From initial planning through follow-up maintenance and service, Delta has the experience to solve all your wastewater handling problems. Delta provides the following services:

- Quotations on all plant components
- In-house engineering and manufacturing
- Jobsite delivery
- Field assembly
- Start-up
- Optional maintenance/service package

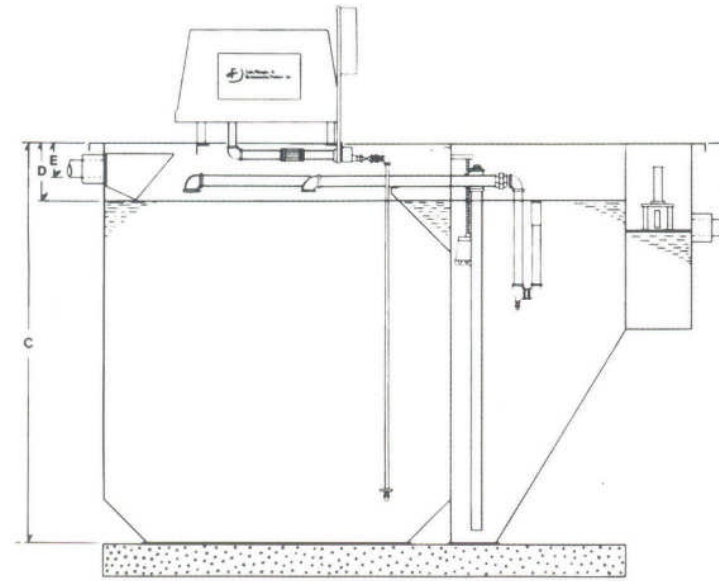
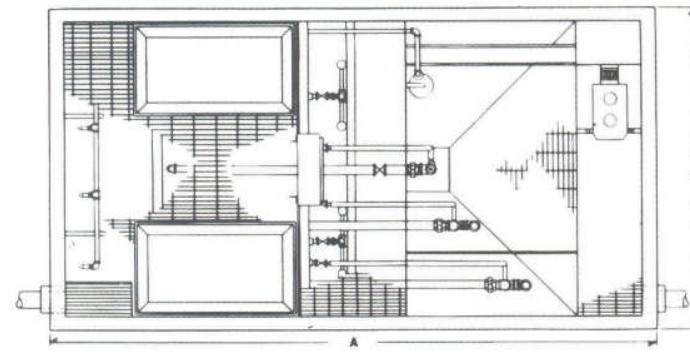

Delta Extended Aeration Plants

DESIGN VOLUME GPD	DIMENSIONS					
	A	B	C	D	E	F
1,000	12' 1"	5' 6"	6' 0"	1' 0"	9"	1' 8"
5,000	19' 2"	7' 8"	9' 4"	1' 4"	9"	2' 2"
10,000	23' 3"	10' 8"	10' 0"	1' 4"	9"	2' 4"
15,000	26' 1"	12' 0"	11' 0"	1' 4"	11"	2' 6"
20,000	35' 2"	12' 0"	11' 0"	1' 4"	11"	2' 6"
35,000	54' 10"	12' 0"	11' 0"	1' 4"	11"	2' 6"
50,000	72' 10"	12' 0"	11' 0"	1' 4"	11"	2' 8"

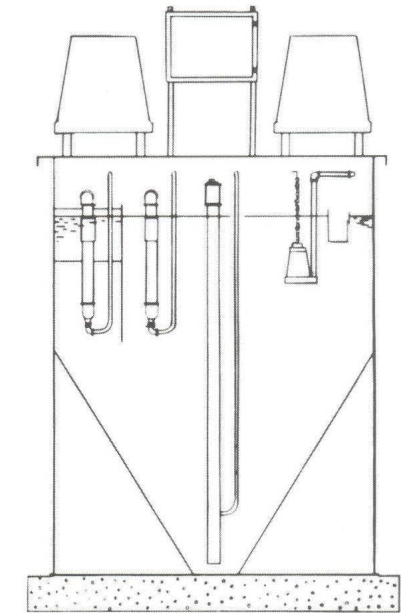

### Packaged lift stations in either:

(a) self-priming or

(b) submersible

Configuration include electrical control panel with alarm

